

STRAIGHT PLUG CRIMP TYPE

R203.075.000

CABLE 2.6/50+75 S

Series : **SSMB**

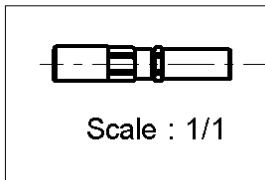
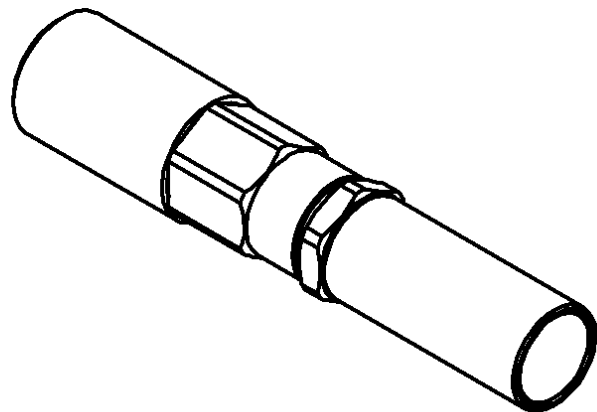
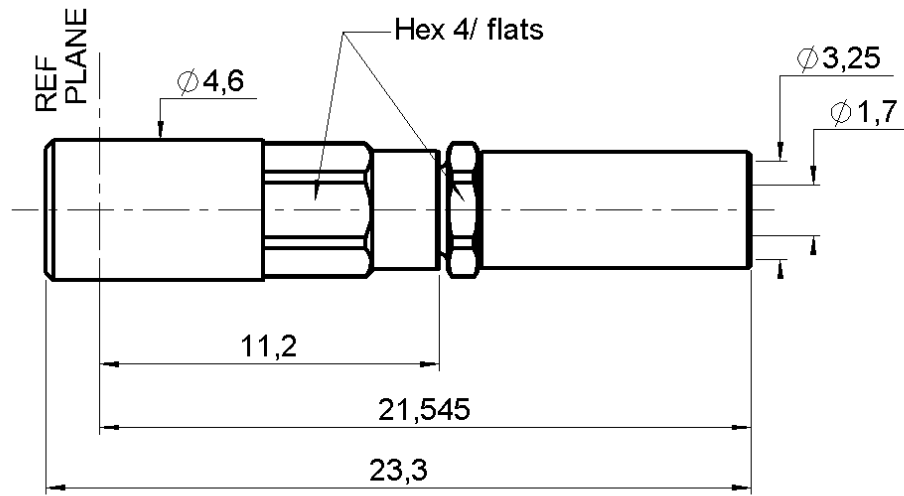

All dimensions are in mm.



COMPONENTS	MATERIALS	PLATINGS (μm)
BODY	BRASS	GOLD 0.5 OVER NICKEL 2
CENTER CONTACT	BERYLLIUM COPPER	GOLD 1.3 OVER NICKEL 2
OUTER CONTACT	BERYLLIUM COPPER	GOLD 0.5 OVER NICKEL 2
INSULATOR	PTFE	
GASKET	-	
OTHERS PARTS	BRASS	GOLD 0.5 OVER NICKEL 2
-	-	-
-	-	-

Issue : 0322 B

In the effort to improve our products, we reserve the right to make changes judged to be necessary.



STRAIGHT PLUG CRIMP TYPE

R203.075.000

CABLE 2.6/50+75 S

Series : **SSMB**

PACKAGING

Standard	Unit	Other
1	-	Contact us

SPECIFICATION

ELECTRICAL CHARACTERISTICS

Impedance		50 Ω
Frequency		0-4 GHz
VSWR	1.25 +	0.030 x F(GHz) Maxi
Insertion loss		0.30 √F(GHz) dB Maxi
RF leakage	- (NA - F(GHz)) dB mini
Voltage rating		175 Veff Maxi
Dielectric withstanding voltage		500 Veff mini
Insulation resistance		1000 MΩ mini

CABLE ASSEMBLY

Stripping	a	b	c	d	e	f
mm	3.50	3.80	11.2	0.00	7.70	0.00

Assembly instruction :

Recommended cable(s)
 RG 174
 RG 179
 RG 187
 RG 174 FTX

Cable retention

- pull off **90** N mini
 - torque **NA** N.cm

MECHANICAL CHARACTERISTICS

Center contact retention		
Axial force – Mating end	8	N mini
Axial force – Opposite end	8	N mini
Torque	NA	N.cm mini

TOOLING

Part Number	Description	Hexagon
.	.	.
R282.235.003	CRIMPING DIES	3.25
R282.293.000	CRIMPING TOOL	-
R282.211.000	CRIMPING TOOL	3.25

Recommended torque		
Mating	NA	N.cm
Panel nut	NA	N.cm
Clamp nut	NA	N.cm
A/F clamp nut	0.000	mm

OTHERS CHARACTERISTICS

Mating life	500	Cycles mini
Weight	0.000	g

ENVIRONMENTAL

Operating temperature	-65/+165	° C
Hermetic seal	NA	Atm.cm3/s
Panel leakage	NA	

Issue : **0322 B**

In the effort to improve our products, we reserve the right to make changes judged to be necessary.



STRAIGHT PLUG CRIMP TYPE

R203.075.000

CABLE 2.6/50+75 S

Series : **SSMB**

COMPONENTS

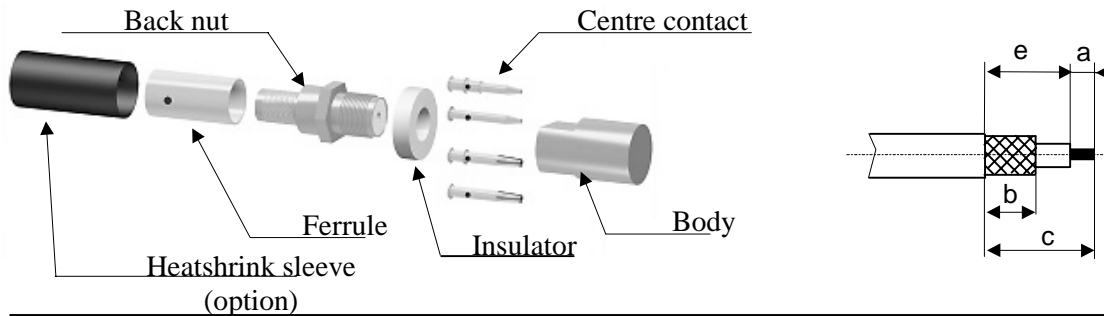

1
Slide the heatshrink sleeve onto the cable (Option).
Slide the ferrule onto the cable.
Position the ferrule's hole at the front if soldering.
Position the ferrule's hole at the back if crimping.
Strip the cable.

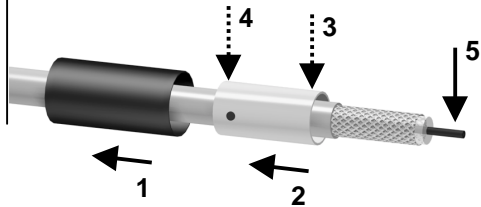

4
Slide the centre contact on until it bottoms against the insulator back nut.
Solder or crimp the contact (see connector TDS).

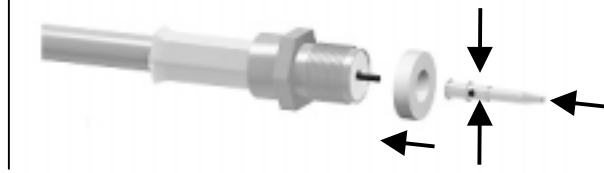

2
Fan the braid.
Slide the cable into the back nut.

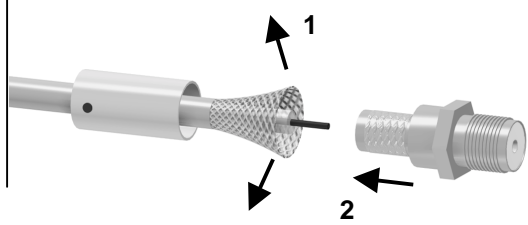

5
Screw the back nut into the connector body with the adapted wrench.
Recommended coupling torque 170 N cm.

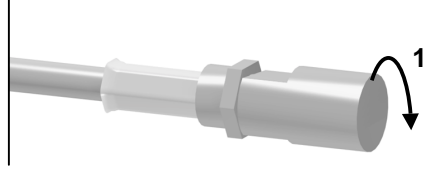

3
Slide the ferrule over the braid.
Crimp the ferrule with crimping tool (see connector TDS).

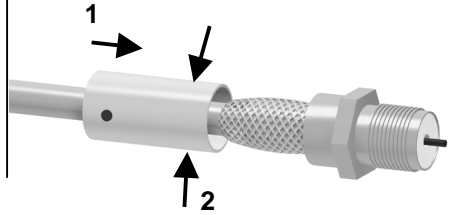

6
Slide the sleeve over the ferrule and heatshrink it in place (option).

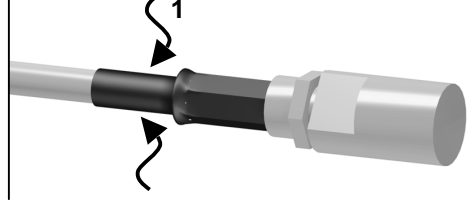

Issue : 0322 B

In the effort to improve our products, we reserve the right to make changes judged to be necessary.

